

RPC-40L8A4 Series

Remote DC Power Control Switches

Quick Start Guide





Warnings and Cautions: Installation Instructions



Secure Racking

If Secure Racked units are installed in a closed or multi-unit rack assembly, they may require further evaluation by Certification Agencies. The following items must be considered.

1. The ambient within the rack may be greater than room ambient. Installation should be such that the amount of air flow required for safe operation is not compromised. The maximum temperature for the equipment in this environment is 45°C. Consideration should be given to the maximum rated ambient.
2. Installation should be such that a hazardous stability condition is not achieved due to uneven loading.

Input Supply

Check nameplate ratings to assure there is no overloading of supply circuits that could have an effect on overcurrent protection and supply wiring.

Grounding

Reliable earthing of this equipment must be maintained. Particular attention should be given to supply connections when connecting to power strips, rather than direct connections to the branch circuit.

No Serviceable Parts Inside; Authorized Service Personnel Only

Do not attempt to repair or service this device yourself. Internal components must be serviced by authorized personnel only.

- **Shock Hazard - Do Not Enter**

Disconnect Power

If any of the following events are noted, immediately disconnect the unit from the circuit and contact qualified service personnel:

1. If the power wire becomes frayed or damaged.
2. If liquid has been spilled into the device or if the device has been exposed to rain or water.

Two Power Supplies

Note that this unit includes two separate power circuits. Before attempting to service or remove this unit, please make certain that both power sources are disconnected.

1. Introduction

This Quick Start Guide describes a simplified installation procedure for the RPC-40L8A4 Series hardware, which will allow you to communicate with the unit in order to demonstrate basic features and check for proper operation. Note that this Quick Start Guide does not provide a detailed description of unit configuration or discuss advanced operating features in detail. For more information, please refer to the User's Guide, which can be found on our web site at the address below, or by scanning the QR Code below.

<http://www.wti.com/uguides>



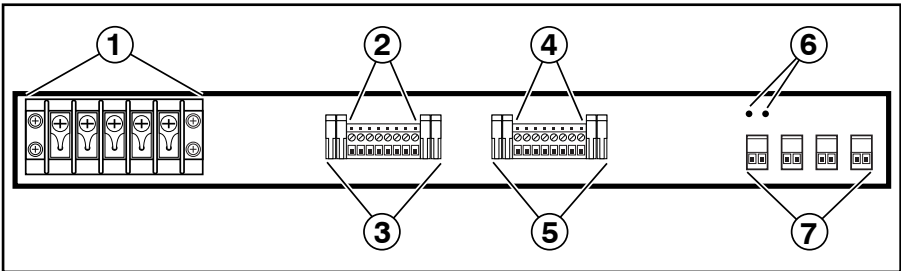

Figure 1: Back Panel (Model RPC-40L8A4 Shown)

2. Back Panel Components

As shown in Figure 1 above, the RPC-40L8A4 Back Panel includes the following:

- ① **Power Input:** Two 40 Amp DC input Buses. The power input terminal block also includes two mounting brackets, which are used to hold the protective cover (not shown).
- ② **Switched Output Circuits - Bus A:** Four 10 amp DC circuits in an output terminal fed by power input bus A. DC output voltages are as follows:
 - RPC-40L8A4-48 = ± 48 V DC, 10 Amps
 - RPC-40L8A4-24 = + 24 V DC, 10 Amps
 - RPC-40L8A4-12 = + 12 V DC, 10 Amps
- ③ **Output Circuit Fuses - Bus A:** Four 10 amp DC GMT fuses that protect circuits on Output Bus A. Ships with 10 Amp fuses; for custom fuses, please contact WTI
- ④ **Switched Output Circuits - Bus B:** Four 10 amp DC circuits in an output terminal fed by power input bus B. Voltages for each RPC-40L8A4 model are described under item 2 above.
- ⑤ **Output Circuit Fuses - Bus B:** Four 10 amp DC GMT fuses that protect circuits on Output Bus B. Ships with 10 Amp fuses; for custom fuses, please contact WTI
- ⑥ **Optional Grounding Lug Location:** Mounting holes for optional grounding lug for 6 gauge ground wire. For more information, please contact WTI.
- ⑦ **Alarm Inputs:** Four alarm inputs, designed for connection to door open alarms or other dry contacts. Each alarm input supplies 0.4 Amps of positive DC current at the same voltage used to power the unit (± 48 V DC units provide +48 V DC, +24 V DC units provide +24 V DC and +12 V DC units provide +12 V DC.)

3. Hardware Installation

Apply Power to the RPC-408LA4

Refer to power rating nameplate on the back panel, and then remove the protective cover from the terminal block and connect the RPC unit to an appropriate power source as shown in Figure 2 below.

Note: RPC-40L8A4 series units feature two completely independent buses, and for each circuit, voltage is connected to the +/- terminal (for negative 48 or positive 48 volt units, power is connected to the +/- terminals and for positive 24 and 12 volt units, positive power is also connected to the +/- terminals.)

Warning: An exposed wire lead from a DC input power source can conduct harmful levels of electricity. Make certain that no exposed portion of the DC input wire extends from the terminal block.

Input voltages for RPC-40L8A4 units are described in the table below:

Model Number	Voltage	Voltage Range
RPC-40L8A4-48	+48 or - 48 VDC	18 to 72 VDC
RPC-40L8A4-24	+24 VDC	18 to 72 VDC
RPC-40L8A4-12	+12 VDC	9 to 36 VDC

When you have finished connecting power lines to the RPC-40L8A4 unit, make certain to replace the protective input terminal block cover.

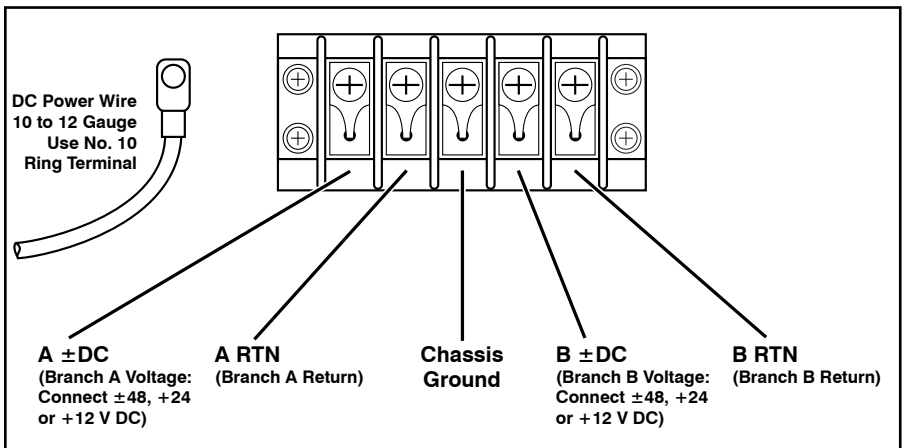

Figure 2: DC Input Terminal Block (Protective Cover Not Shown)

Connecting Switched Devices to the RPC

The output terminals on the RPC back panel are used to connect DC voltage to each switched device. Each output terminal includes eight connectors (four circuits.) To connect wires to the DC output terminal block, proceed as follows:

Notes:

- Each individual output circuit will support up to 10 Amps maximum; the total for all four circuits on either bus cannot exceed 40 Amps.
- When tightening or loosening the terminal block retaining screws, use a screwdriver with a 3mm wide blade.

Warning: An exposed wire lead from a DC input power source can conduct harmful levels of electricity. Make certain that no exposed portion of the DC input wire extends from the terminal block.

1. Prior to inserting a wire into the the DC terminal block, you must use loosen the retaining screw in order to allow the wire to enter the wire hole. Use a screwdriver with a 3mm wide blade to turn the retaining screw all the way to the left.
2. Firmly insert the wire into the wire hole and push the wire into the hole until resistance is felt.
3. While holding the wire in place, use a screwdriver with a 3mm wide blade to tighten the retaining screw; the screwdriver that is used to tighten the retaining screw must be narrow enough to reach the retaining screw unobstructed. Note that in order to properly secure the wire, you must push down on the screwdriver while tightening the retaining screw until the screw is firmly seated.

Note: If you have difficulty securing the wire to the terminal block, make certain that you are using a screwdriver with a 3 mm wide blade (or narrower,) and that the retaining screw and is tight enough to hold the wire in place.

Caution: Do not over tighten the retaining screws. The recommended maximum torque is 4.5 lbf-in (72 ozf-in.)

4. Tug on the wire to make certain that the wire is firmly held in place.

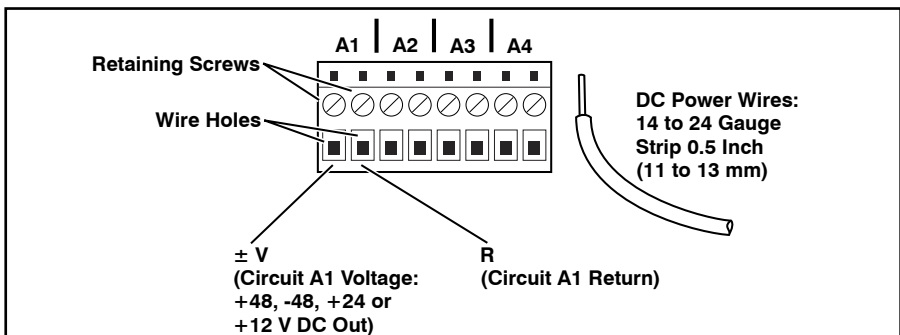

Figure 3: DC Output Terminal Blocks (Fuses Not Shown)

Output Terminal Fuses

Note that each output terminal includes four fuses; one for each circuit on the output terminal. If a fuse is blown, a red dot will appear in the clear cap as shown in Figure 4. To remove a fuse, use a pair of pliers to grasp the black body of the fuse, and then gently pull the fuse loose from the RPC unit. The RPC ships with 10 Amp fuses; for custom fuses, please contact WTI.

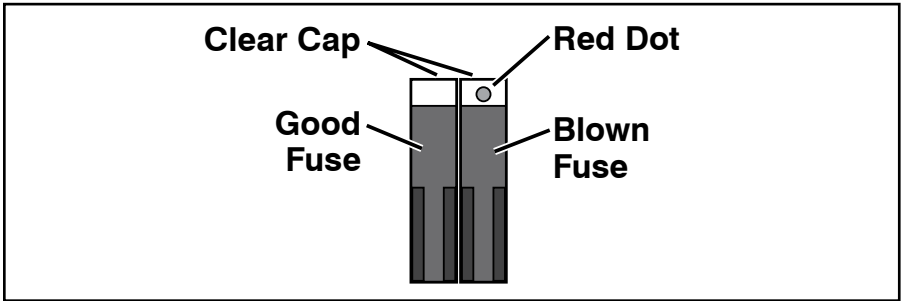

Figure 4: DC Output Terminal Block Fuses

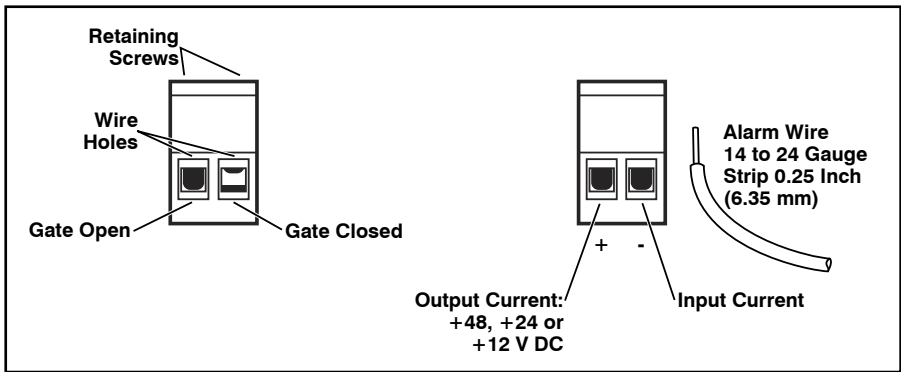

Figure 5: Connecting to the Alarm Inputs

Connecting to the Alarm Inputs

The RPC-40L8A4 back panel includes four alarm inputs, designed for connection to door open alarms or other dry contact alarms. Each + pin supplies positive DC voltage at the same voltage that is used to power the unit (i.e., ± 48 V DC units provide +48 V DC, +24 V DC units provide +24 V DC and +12 V DC units provide +12 V DC.)

Note that when the RPC-40L8A4 unit is shipped from the factory, the removable alarm input connectors are enclosed in separate plastic bag, included in the shipping box and must be installed by the user.

When connecting wires to alarm inputs, make certain each wire is properly seated and firmly held in place by the retaining screw. As shown in Figure 5, in order to properly seat the wire the retaining screw must be turned counter-clockwise until the metal "gate" in the wire hole is open. If the metal gate is closed, the wire will not seat properly. After inserting the wires, tighten both screws to secure the wires to the connector and snap the connector in place on the back panel of the RPC unit.

Caution: Do not over tighten the retaining screws. The recommended maximum torque is 4.5 lbf-in (72 ozf-in.)

4. Connect your PC to the RPC

Switch on power to the RPC unit; the ON LED should light, and the RDY LED should begin to flash. This indicates that the RPC is ready to receive commands.

The RPC can either be controlled by a local PC, that communicates with the unit via cable, controlled via external modem, or controlled via TCP/IP network. Note that it is not necessary to connect to both the Network and Console Ports, and that the Console Port can be connected to either a local PC or External Modem.

- **Network Port:** Connect your 10Base-T or 100Base-T network interface to the RPC Network port.
- **Console Port:** Use the null modem cable supplied with the unit to connect your PC COM port to the RPC Console (RS232) Port.
- **External Modem:** Use a standard AT or modem cable to connect your external modem to the RPC's Console (RS232) Port.

5. Communicating with the RPC

In order to ensure security, both Telnet and Web Browser Access are disabled when the RPC is shipped from the factory. To enable Telnet and/or Web Browser access, please refer to the RPC User's Guide. When properly installed and configured, the RPC will allow command mode access via Telnet, Web Browser, SSH client, modem, or local PC. Note that SSH is enabled by default, but can disabled via the Network Parameters menu as described in Section 5.9.2.

Notes:

- Default RPC serial port parameters are set as follows: 9600 bps, RTS/CTS Handshaking, 8 Data Bits, One Stop Bit, No Parity. Although these parameters can be easily redefined, for this Quick Start procedure, it is recommended to configure your communications program to accept the default parameters.
- The RPC features a default IP Address (192.168.168.168) and a default Subnet Mask (255.255.255.0.) This allows network access to command mode, providing that you are contacting the RPC from a node on the same subnet. When attempting to access the RPC from a node that is *not* on the same subnet, please refer to the User's Guide for further configuration instructions.

1. **Access Command Mode:** The RPC includes two separate user interfaces; the Text Interface and the Web Browser Interface. The Text Interface is available via Local PC, SSH Client, Telnet, or Modem. The Web Browser interface is only available via TCP/IP network.
 - a) **Via Local PC:** Start your communications program and then press **[Enter]**.
 - b) **Via SSH Client:** Start your SSH client, enter the default IP address (192.168.168.168) for the RPC and invoke the connect command.
 - c) **Via Web Browser:** Make certain that Web Browser access is enabled as described in the RPC User's Guide. Start your JavaScript enabled Web Browser, enter the default RPC IP address (192.168.168.168) in the Web Browser address bar, and then press **[Enter]**.
 - d) **Via Telnet:** Make certain that Telnet access is enabled as described in the RPC User's Guide. Start your Telnet client, and enter the RPC's default IP address (192.168.168.168).
 - e) **Via Modem:** Make certain that the RPC Console Port has been configured for Modem Mode as described in the RPC User's Guide, then use your communications program to dial the number for the external Modem connected to the Setup Port.
2. **Username / Password Prompt:** A message will be displayed, which prompts you to enter your username and password.. The default username is "**super**" (all lower case, no quotes), and the default password is also "**super**". If a valid username and password are entered, the RPC will display either the Circuit Control Screen (Web Browser Interface) or the Circuit Status Screen (SSH, Telnet, or Modem).
3. **Test Switching Functions:** You may wish to perform the following tests in order to make certain that the RPC is responding to commands. When switching and reboot commands are executed, the Status LED(s) will also turn On or Off to indicate the current status of the circuit(s).
 - a) **Reboot Circuit:**
 - i. **Web Browser Interface:** Click on the "Circuit Control" link on the left hand side of the screen to display the Circuit Control Menu. From the Circuit Control Menu, click the down arrow in the row for Circuit 1 to display the dropdown menu, then select "Reboot" from the drop down menu and click on the "Execute Actions" button.
 - ii. **Text Interface:** Type **/BOOT 1** and press **[Enter]**.

b) **Switch Circuit Off:**

- i. **Web Browser Interface:** From the Circuit Control Menu, click the down arrow in the "Action" column for Circuit 1 to display the drop down menu, then select "Off" from the drop down menu and click on the "Execute Actions" button.
- ii. **Text Interface:** Type **/OFF 1** and press **[Enter]**.

c) **Switch Circuit On:**

- i. **Web Browser Interface:** From the Circuit Control Menu, click the down arrow in the "Action" column for Circuit 1 to display the drop down menu, then select "On" from the drop down menu and click on the "Execute Actions" button.
- ii. **Text Interface:** Type **/ON A1** and press **[Enter]**.

This completes the Quick Start Guide for the RPC-40L8A4. Prior to placing the unit into operation, it is recommended to refer to the RPC User's Guide for important information regarding advanced configuration capabilities and more detailed operation instructions. If you have further questions regarding the RPC unit, please contact WTI Customer Support as described in the User's Guide.



5 Sterling • Irvine • California 92618
(949) 586-9950 • Toll Free: 1-800-854-7226
Fax: (949) 583-9514 • <http://www.wti.com>