

1. Overview:

Dataprobe's Redundancy Switching System (RSS) provides reliable switchover of communications circuits for line protection and equipment redundancy applications. Create fault-tolerant systems with either simultaneous (gang) switching or independent control of each A/B switch.

These physical layer (Layer 1) switches allow redundant systems to be automatically, remotely or manually operated, insuring maximum uptime for critical communication circuits.

Relay based switch modules insure communications, even when power is removed or control connections are down. This fail soft technology is optimized for applications including:

- Disaster Recovery
- Air Traffic Control
- Network Operations
- SCADA
- Computer Telephony
- Data Center Hotsite
- E911 Safety
- Trunking Redundancy

Multiple remote control options allow many configurations possible. Network control from SNMP Manager, web browser or Telnet interface makes the system accessible from any network location. Serial port control via modem or direct connection provides out-of-band access when the network is down.

Both serial and network interfaces provide communication with user friendly menus or web browser interfaces. Each A/B card in the system can be named for easy identification. Cards can be grouped and switched together or independently.

For system developers, the K-16 series offers direct command control, both via the serial port and via UDP network messaging. This allows direct program control by Network Management Systems, customized user interfaces, or easily integrated into OEM systems and software.

In addition to the remote control capabilities, the system can be controlled manually with system, chassis and individual A/B circuit resolution. A remote switch and status display panel is available to remote the manual switches up to 1000' from the switch assembly. A/B switch cards are available in standard communication interfaces.

Each A/B switch card includes the proper connectors; no additional interface modules are required. A/B switch cards support all the leads in their respective interfaces, making them ideal for a wide variety of circuit arrangements.

2. RSS System Components

The modular nature of the RSS makes it easy to configure a system to your exact specifications. There are four component categories that need to be selected in configuring any RSS system.

- Chassis
- Power
- Control
- Switch

2.1. Chassis

The RSS system chassis provides a means of mounting all the other components. RSS chassis are designed for mounting in EIA-310 (19" wide) equipment racks. Two chassis are offered for the RSS system:

Chassis Model	RSS-16	RSS-3
Ordering Code (SKU)	1150101	1150102
Chassis Height	7" (4U)	1.75" (1U)
Number of Power Bays	2	1
Number of Control Bays	2	1
Number of A/B Bays	16	3

Figure 2.1
RSS-16 Chassis, Rear View

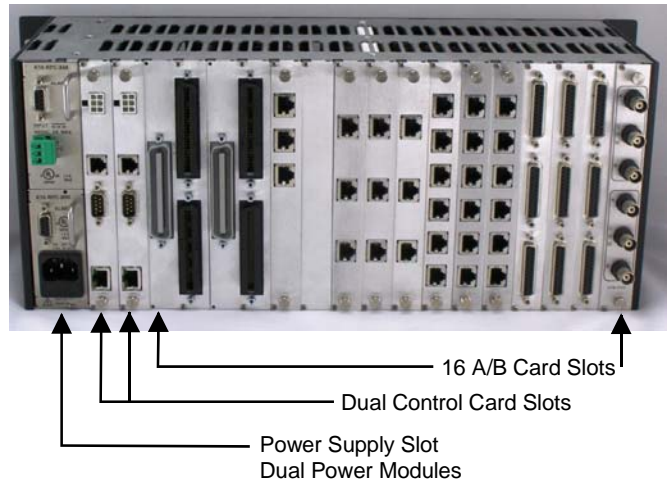

The RSS-16 chassis has gang control switch buttons with protection against inadvertent actuation.

Figure 2.2
RSS-3 Chassis, Rear View

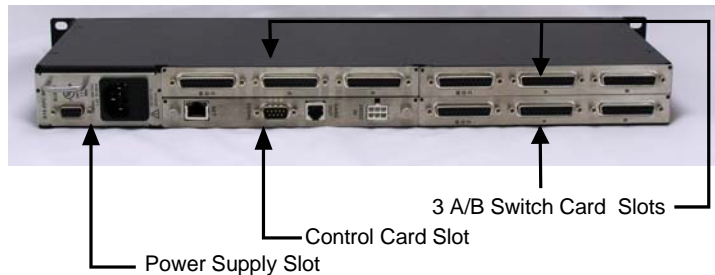

The RSS-3 chassis contains only one power supply bay. To achieve dual redundant power for the RSS-3 chassis, use one internal power supply and one external power supply. External power supplies are connected to any of the control cards.

2.2. Control Cards

Control cards provide the means to interface with the RSS system to remotely manage and operate the system.

2.2.1. IPC-16-R Network and Serial Control Card

This control card provides both In-Band and Out-of-Band remote control for almost every application. This card supports individual control of 16 A/B Switch cards plus group and gang control for an unlimited number of switches. The Network/Serial control card has both a 10base-T network port and a RS-232 Serial Port. Control via simple web clicks or telnet menus. Each A/B Card can be named for easy identification.

The IPC-16-R provides Web, Telnet, SNMP management, standard.

For system designers, control can also be via direct TCP messaging. The control protocol and programmer support is freely available. A serial port provides direct or modem connection when the network is unavailable.



2.2.2. IPC-AUTO-16-R Network and Serial Control Card for Auto A/B

This card is identical to the IPC-16-R, but is designed to be used with the automatic switching cards, like AB-232-R. In all other cases, use the IPC-16-R control card.

2.2.3. IPC-1-R Network Control Gang Card

This control card provides simple web browser control for a single A/B switch or an unlimited number of ganged (simultaneously controlled) A/B switches.

The unique AutoPing feature allows automatic detection of failed systems with programmable automatic failover and switchback based on system availability.

For system designers, control can also be via direct TCP messaging. The control protocol and programmer support is freely available.

Note: This card requires two control card slots in the RSS-16 and one control card slot and one A/B card slot in the RSS-3.



2.2.4. IOC-16-R I/O Control Card – 16

The IOC-16-R provides wiring access for external contact control and switch card status monitoring. It can be installed along with a IPC-16-R Network Control access card or with a IOC-16-R gang access card.

The IOC-16-R uses 50 Pin Amphenol (Telco) connectors to provide access to the control inputs and status outputs.

Note: This control card does not provide a 24VDC input for power.



2.2.5. IOC-3-R I/O Control Card – Gang

Model IOC-3-R provides three contact closure inputs and status relay outputs for RSS-3 and RSS-16 systems for single switch or multi-switch ganged (simultaneous controlled) system. Up to three A/B switch cards can be independently controlled.

The IOC-3-R installs in the control slot of the RSS-3 or RSS-16 chassis to provide remote relay control of an unlimited number of ganged switch cards. In multi-chassis ganged systems, this controller accepts control inputs from IPC-1-R, IPC-3-R IPC-16-R or any external contact closure.



2.2.6. Control Card Comparison Chart

Control Card Model	IPC-16-R	IPC-1-R	IOC-16-R	IOC-3-R
Ordering Code (SKU)	1930065	1930079	1930066	1930073
Web Browser Control	X	X		
Telnet Control	X			
SNMP Manageable	X	X		
AutoPing Control		X		
Serial Control	X			
Individual Card Control	X		X	
Gang Card Control	X	X	X	X
GPIO Control and Status			X	X

2.2.7. Multi Chassis Gang Systems

The IPC-1, IPC-16 and IOC-3 control cards feature a Gang Out connector. This modular jack connection mates to a Gang In connector on the IOC-3, making it easy to link multiple cards together to create gang switching systems of unlimited size.

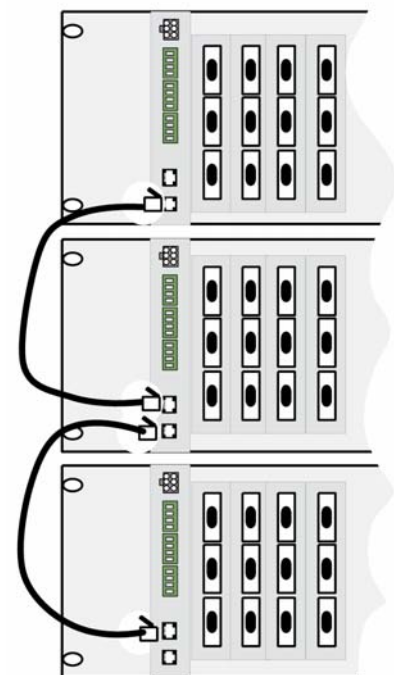

*Figure 2.3
Link Multiple Chassis for Gang Applications.*

2.3. Power Supplies

The RSS chassis supports both internal and external power supplies, allowing a wide assortment of combinations for flexibility and redundancy. Internal power modules are available to support worldwide A/C power, -48VDC and +24VDC power supplies. External power supplies provide redundancy either when used in pairs, or when combined with an internal module.

2.3.1. K-RPC-WRI A/C Power Supply. 100-240VAC

This A/C power supply is used for applications requiring UL listing. It is supplied with a NEMA 5-15 linecord.

Input Power	Nominal : 120/240 VAC 50/60 Hz Range : 100 - 240 VAC Watts: 50 Fusing: 2 A
AC Input	IEC 320 C14 Linecord for North America Included
Environmental	Operating: 0 C - +65C



2.3.2. PS-RSS-WRI A/C Power Supply. 100-240VAC

This is the same supply as K-RPC-WRI with UL approvals pending. . It is supplied with a NEMA 5-15 linecord.

Input Power	Nominal : 120/240 VAC 50/60 Hz Range : 100 - 240 VAC Watts: 50 Fusing: 2 A
AC Input	IEC 320 C14 Linecord for North America Included
Environmental	Operating: 0 C - +65C

2.3.3. PS-RSS-48 48VDC Power Supply

This power supply is for 48VDC applications. Two can be used in the RSS-16 chassis to provide dual redundant power, and can be mixed with K-RPC-WRI or PS-RSS-WRI for mixed power applications.

Input Power	Nominal : 48VDC Range : 42 - 60 VDC Watts: 75 Fusing: 2.5 A
DC Input	Screw Terminals
Environmental	Operating: 0 C - +65C



2.3.4. PS-WRI-4 External A/C Power Supply

This power supply can be used as a lower cost alternative to the internal power supply in the RSS-3 chassis. It can also be used as a redundant power supply in conjunction with any internal power supply. The power supply installs in all control cards except IOC-16-R. It does not supply enough power for RSS-16 applications.



2.4. A/B Cards

All of the A/B cards provide physical layer switching for their supported interface. All cards support all pins in their interface, making them ideal for a wide variety of environments.

Each A/B Card has three connectors, Common, A and B and forms a complete A/B switch. No other modules or interfaces are required. The A/B cards use latching relays and will maintain connectivity on the currently switched port regardless of loss of power or control interface.

Each A/B card has two LED indicators that illustrate current switch position. These LEDs are viewed from the front panel of each chassis. Each A/B card has a momentary toggle switch to manually control the switch position.

All connectors use are female, except as noted below.

Model / SKU	Interface / Notes
AB-232-R 1120208	Auto Switch/Monitor Card
AB-D9-R 1110206	9 Pin D'Subminiature
AB-D15-R 1110212	15 Pin D'Subminiature
AB-D25-R 1110200	25 Pin D'Subminiature
AB-2RJ8-R 1110202	Dual 8 Wire Modular Jack. All applications up to 1G Ethernet.
AB-2BNC-R 1110211	Dual BNC/DS-3 AB Card. This card is suitable for up to DS-3 (45Mhz)
AB-M34-R 1110205	V.35 with M34 Winchester Connectors
AB-T50-R 1110204	50 Pin Telco (Amphenol, RJ21X). Common Connector is Male. Note: This card requires 2 slots in the chassis. Only one card can be accommodated in the RSS-3
FP-AB-RSS 1920128	Blank Panel for unused slots. Blank panels required for unused slots to meet FCC15 and UL/CE radiation compliance.

Additional interfaces are available on special order. Contact Dataprobe with your requirements.

2.4.1. AB-232-R Auto Switch Card

The AB-232-R Auto Switch and Monitor card provides real-time lead sensing, with alarm generation and conditional auto switching based on user programmed conditions.

The Auto Switch and Monitor card can be used independently, or as a master switch for other switch modules in the RSS system. Auto Switch and Monitor Cards can support RS-232 or RS-530 interfaces.

The Auto Switch and Monitor card continuously monitors and displays the status of the following leads in either RS-232 or RS-530 (balanced) signals:

- TD
- RD
- RTS
- CTS
- DSR
- DTR
- DCD

Two of these leads can be used to create Auto Switching algorithms, with time qualifying and Boolean logic parameters. Once pre-set conditions are met, automatic failover and auto switchback (if programmed) occur. Network managers are alerted to any change of state through SNMP traps and email notification.



3. Legacy Products Now in RSS Family

Dataprobe's Redundancy Switching System represents a re-organization of several of Dataprobe's successful switching solutions into an integrated product line. The RSS family includes elements from the following existing product families, and builds a coordinated framework for designing and managing physical layer redundancy switching solutions:

- K-16 5U A/B Switch System for multiple (16) circuits
- K-3 1U A/B Switch System for multiple (3) circuits
- iP-AB Web Controlled A/B switches

RSS Model

Item	Model	Description
Chassis		
1150101	RSS-16	RSS 16 Slot 4U Chassis
1150102	RSS-3	RSS 3 Slot 1U Chassis
Power Supplies		
1930069	PS-RSS-WRI	A/C Power Module 100-240VAC
1930070	PS-RSS-48	48VDC Power Supply
1930081	PS-RSS-24	Dual Power Access Supply
1930076	PS-WRI-4	External A/C Power Supply (RSS-3 only)
1920031	FP-PS-RSS	Filler Panel, RSS Series Power Supply
Control Cards + Options		
1340065 1340079	IPC-16-R IPC-AUTO-16-R	Network and Serial Control Card
1340066	IPC-1-R	Network Control Gang Card
1340067	IOC-16-R	I/O Control Card - 16
1340073	IOC-3-R	I/O Control Card - Gang
A/B Switching Cards		
1110206	AB-D9-R	9 Pin D'Subminiature
1110212	AB-D15-R	15 Pin D'Subminiature
1110200	AB-D25-R	25 Pin D'Subminiature
1110202	AB-2RJ8-R	Dual 8 Wire Modular Jack up to 1G Ethernet
1110211	AB-2BNC-R	Dual BNC/DS-3 AB Card
1110205	AB-M34-R	V.35 with M34 Winchester Connectors
1110204	AB-T50-R	50 Pin Telco (Amphenol, RJ21X).
1920128	FP-AB-RSS	Blank Panel for unused slots
1120208	AB-232-R	Auto Switch/Monitor Card

Legacy Model Replaced

Item	Model	Description
Chassis		
1150050	K-AB-R-16L	K-16 Series Chassis 5U
1150100	K3-R	K-3 Series Chassis 1U
Power Supplies		
1930069	K16-RPC-WRI	A/C Power Supply
1930070	K16-RPC-48	48VDC Power Supply
1930079	PS-R1-224	Dual Power Access Module
1930061	K16-XPS	External A/C Power Supply
1920019	K-AB-PS-FP	Blank Panel for unused P/S Slot
Control Cards + Options		
1340048 1340050	IP-K16-R CP-K16-R	Network and Serial Control Cards
1340049	T-K16-R	Extended I/O Control Card
1340044 1340063	G-K16-R C-AB-1-R	Gang Control / Expansion Cards.
A/B Switching Cards		
1110051	K16-D9-L-R	9 Pin D'Subminiature
1110050	K16-D15-L-R	15 Pin D'Subminiature
1110053	K16-D25-L-R	25 Pin D'Subminiature
1110057 1110068	K16-2RJ8-L-R K16-RJ1X-L-R	Dual 8 Wire Modular Jack up to 16 Mhz High Speed Ethernet 10/100/1000
1110056 1110052 1110060	K16-BNC-L-R K16-2BNC-L-R K16-DS3-L-R	Dual BNC, up to 16 Mhz Dual BNC, up to 16 Mhz Dual BNC for 45 Mhz DS-3
1110067	K16-M34-L-R	V.35 with M34 Winchester Connectors
1110055	K16-T50-L-R	50 Pin Telco (Amphenol, RJ21X).
1920023	K16-Blank	Blank Panel for unused slots

Dataprobe Inc
1 Pearl Court, Suite B
Allendale New Jersey 07401

Technical Support
tech@dataprobe.com 201-934-5111
www.dataprobe.com/support 201-934-9944