



BusWorks® 900PB Series Profibus/RS485 Network I/O Modules

Model 961PB-2006 Six Differential Current Inputs
Model 962PB-2006 Six Differential Voltage Inputs

USER'S MANUAL



ACROMAG INCORPORATED
30765 South Wixom Road
Wixom, MI 48393-2417 U.S.A.

Tel: (248) 624-1541
Fax: (248) 624-9234

Copyright 2002, Acromag, Inc., Printed in the USA.
Data and specifications are subject to change without notice.

8500692D

TABLE OF CONTENTS

Symbols on equipment:



Means Refer to User's Manual (this manual) for additional information".

The information of this manual may change without notice. Acromag makes no warranty of any kind with regard to this material, including, but not limited to, the implied warranties of merchantability and fitness for a particular purpose. Further, Acromag assumes no responsibility for any errors that may appear in this manual and makes no commitment to update, or keep current, the information contained in this manual. No part of this manual may be copied or reproduced in any form without the prior written consent of Acromag, Inc.

IMPORTANT SAFETY CONSIDERATIONS

You must consider the possible negative effects of power, wiring, component, sensor, or software failure in the design of any type of control or monitoring system. This is very important where property loss or human life is involved. It is important that you perform satisfactory overall system design and it is agreed between you and Acromag, that this is your responsibility.

GETTING STARTED

MOUNTING AND DIMENSIONS.....	3
CONTROLS & INDICATORS.....	3
ISOLATION BARRIERS.....	3
SETTING SLAVE ADDRESS.....	4
CONNECTIONS.....	4
DIN-Rail Mounting And Removal.....	4
Network.....	5
Power.....	6
Analog Inputs.....	6
Earth Ground.....	8
TROUBLESHOOTING.....	8
Tips For Building Profibus Networks.....	9
Top Four Common Profibus Problems.....	9
Troubleshooting Tools.....	9
Using Connectors To Troubleshoot.....	10
Diagnostics Function.....	10
Diagnostics Table.....	10
CALIBRATION.....	11

TECHNICAL REFERENCE

KEY FEATURES.....	13
HOW IT WORKS.....	14
SPECIFICATIONS.....	15
Model Numbers.....	15
Analog Inputs.....	15
General Specifications.....	16
Agency Approvals.....	16
Enclosure/Physical.....	16
Environmental.....	17
Communication Interface.....	18
Controls & Indicators.....	19
Data Types.....	19
Module Specific Parameters.....	20

Windows® is a registered trademark of Microsoft Corporation.
 Profibus® is a registered trademark of Profibus Trade Organization.
 All trademarks are the property of their respective owners.

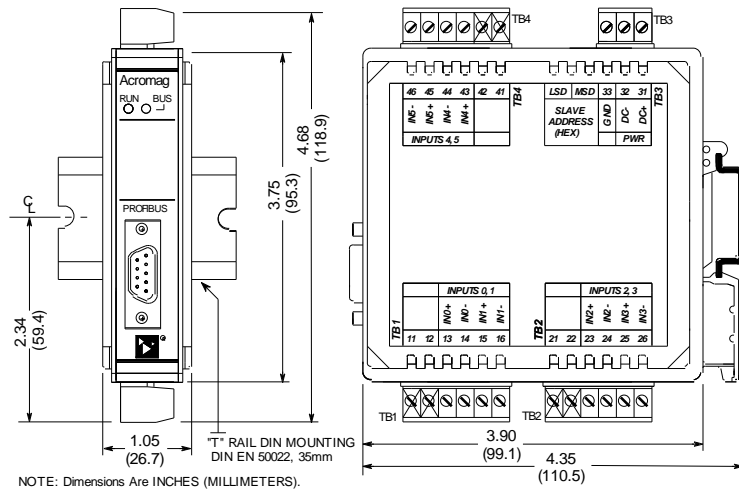

MODEL 961/962PB ENCLOSURE DIMENSIONS

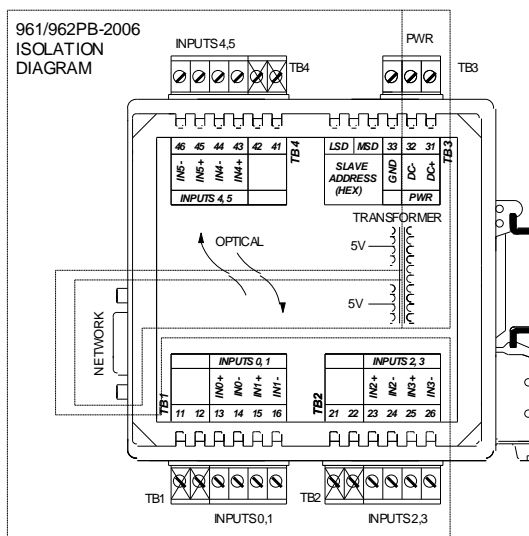
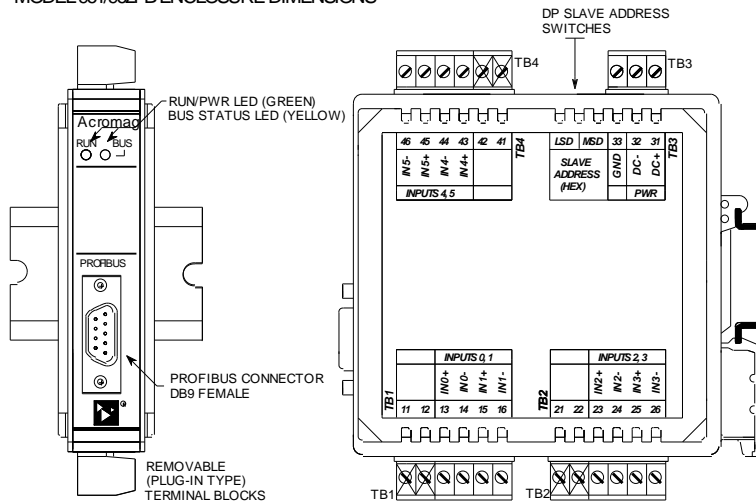

MOUNTING AND DIMENSIONS

Unit mounts to "T" type DIN rails (35mm, type EN50022).

Units may be mounted side-by-side on 1-inch centers.

WARNING: IEC Safety Standards may require that this device be mounted within an approved metal enclosure or sub-system, particularly for applications with exposure to voltages greater than or equal to 75VDC or 50VAC.

CONTROLS & INDICATORS

Green Run LED will stay ON if power is on and unit is OK, and will blink if unit fails.

Yellow BUS LED will turn ON if module is properly connected to the network and in data exchange mode.

ISOLATION BARRIERS

Dashed Lines denote isolation barriers.

The input circuit, network, and power circuit are isolated from each other for safety and noise immunity.

SETTING SLAVE ADDRESS

Address is set to 126 (7EH) from the factory. This address is reserved for commissioning purposes only.

Locate hexadecimal address switches in recessed opening next to the power terminals.

Use a screwdriver to rotate these switches to set a unique valid address from 0 to 125.

If the switches are set to a valid address from 0-125, then the switch setting determines the slave address and the Set Slave Address software command will be rejected.

If these switches are instead set to 126 (7EH) upon power-up, the unit will retrieve its address from the internal EEPROM, which is modified via the Set Slave Address command.

If these switches are set to 255 (FFH) upon power-up, this will return the address stored in EEPROM to 126 (7EH).

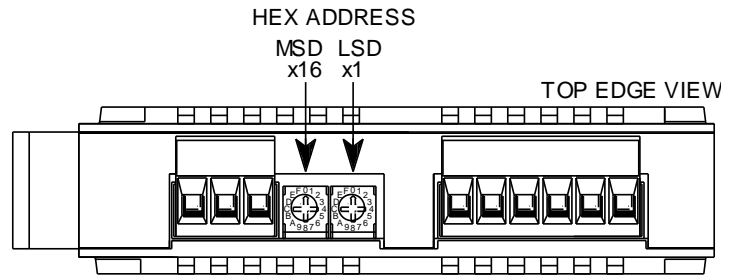

SET SWITCHES TO A VALID SLAVE ADDRESS FROM 0 TO 125 (00H TO 7DH)

- Choose a slave address from 0-125 and locate highest MSD number less than this address. Set MSD switch to this number's corresponding HEX digit.

MSD x16		0	16	32	48	64	80	96	112	128	144	160	176	192	208	224	240
HEX		0	1	2	3	4	5	6	7	8	9	A	B	C	D	E	F
LSD x1	DEC	0	1	2	3	4	5	6	7	8	9	10	11	12	13	14	15
HEX		0	1	2	3	4	5	6	7	8	9	A	B	C	D	E	F

- Determine the DECimal remainder and set the LSD switch to its corresponding HEX digit.

The address stored in the internal EEPROM is modified via the Set Slave Address command. If the address switches are set to 126 (or 126 to 254) upon power-up, the module will retrieve the last address stored within its EEPROM (126 from the factory). With both the internal EEPROM and external switch addresses set to 126, the unit will await the Set Slave Address command after power-up, before proceeding to the parameterization state (address 126 cannot be used in data exchange mode and is reserved for commissioning purpose only). You must use the Set Slave Address command to change the internal (EEPROM) address following power-up in order to proceed. However, if the switches are set to an address less than 126 upon power-up, then the switches determine the slave address and the EEPROM setting is ignored. You can later restore the internal EEPROM setting to 126 by powering the unit up with the address switches set to 255 (FF). You would then power the unit up again with these switches set to 126 in order to return the unit to its commissioning state.

CONNECTIONS

DIN-Rail Mounting & Removal

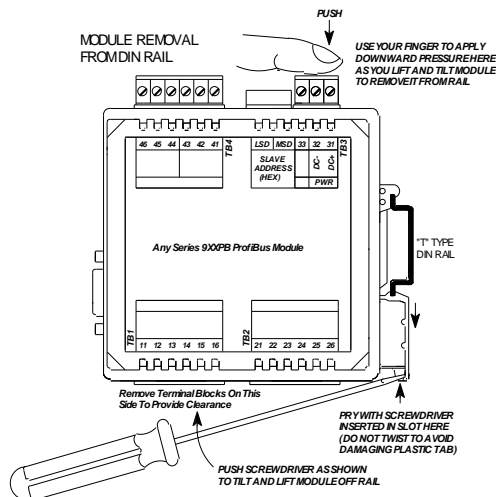

When attaching the module to the T-type DIN rail, angle the top of the unit towards the rail and locate the top groove of the adapter over the upper lip of the rail. Firmly push the unit towards the rail until it snaps into place. To remove, first separate the input terminal block(s) from the bottom side of the module to create a clearance to the DIN mounting area. Next, while holding the module in place from above, insert a screwdriver into the lower arm of the DIN rail connector and use it as a lever to force the connector down until the unit disengages from the rail (do not twist the screwdriver to avoid damaging plastic).

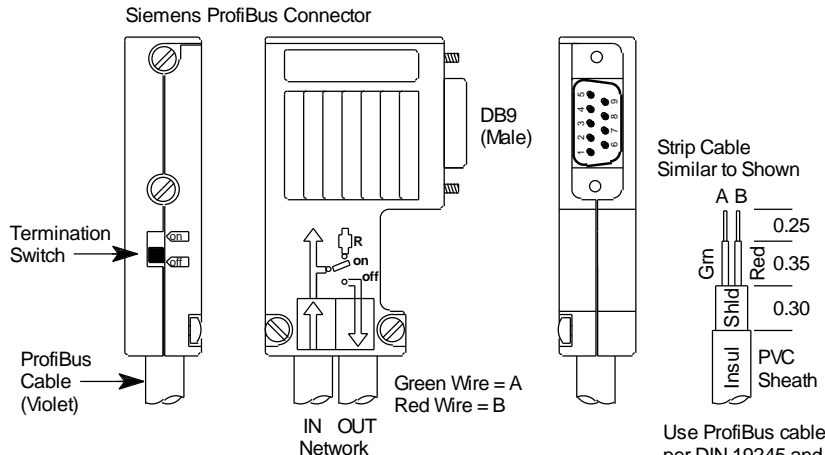

Do not mix RS485 A & B connections. Green wire is A, red wire is B. You MUST terminate the network at both ends only. Termination resistors are integrated in the Profibus connector. When you switch termination ON, the out-going connections are disconnected from the network.

CONNECTIONS

Network

Use Profibus connectors similar to the one shown at right (Siemens version shown).

Always use Profibus cable per DIN 19245 and EN 50170.

When building cables, do not mix A & B connections. Green wire is A, Red wire is B.

The connector must have built-in inductors in order to operate at the higher baud rates.

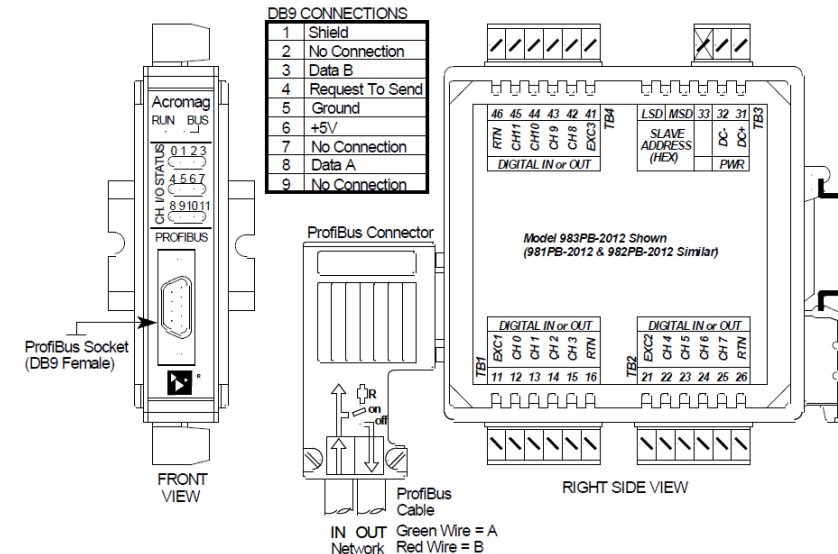

Network Length

Use Type A Profibus cable per EN 50170. Keep line lengths less than the length indicated below for your transmission rate. For baud rates not shown, the lower length of the closest range end points apply (i.e. 100M at 3Mbps).

Bus Segment Length Limit Per Baud Rate For Type A Bus Cable

BAUD	9.6K	19.2K	93.75K	187.5K	500K	1.5M	12M
Type A	1200M	1200M	1200M	1000M	400M	200M	100M

Termination

The network must be terminated at both ends only. Most Profibus connectors include a switch for termination as shown above. Note that this switch will also disconnect the outgoing network signal.

GSD Files:

961PB-2006: ACRO0704.GSD
Ident_Number=0704H

962PB-2006: ACRO0703.GSD
Ident_Number=0703H

IMPORTANT: Do not connect earth ground to logic Ground (DB9 Pin 5). Earth Ground should connect to cable Shield (common to DB9 Pin 1).

Note that Acromag modules also support the optional RTS direction control signal at Pin 4.

Network

Example Profibus System Connections

Up to 125 slave modules may network together with a class 1 master using four repeaters (one repeater every 31 nodes). Address 0 is typically reserved for the class 1 master.

Note: 12Mbps installations require a minimum cable length of 1M between stations.

TIP: A recommended RS485 repeater for Profibus is the Siemens 6ES79720AA01-0XA0.

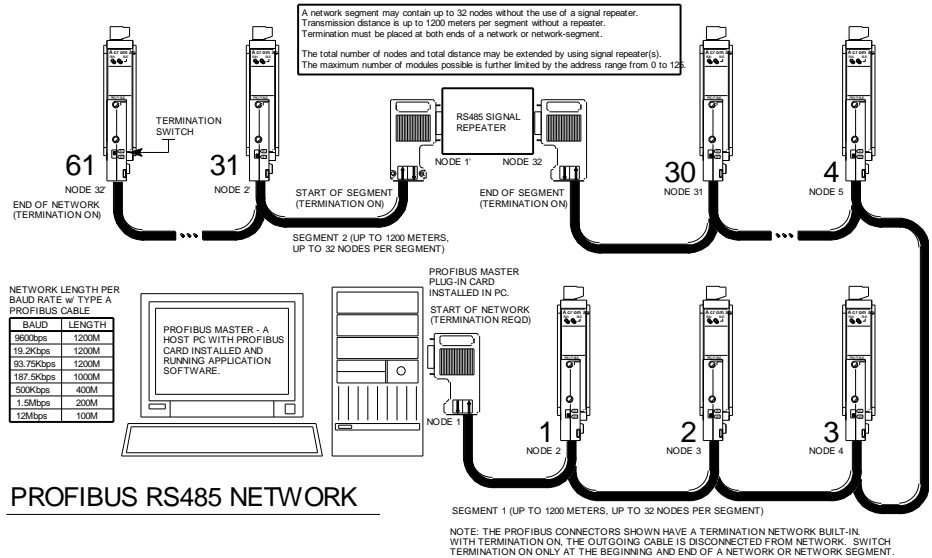

PROFIBUS RS485 NETWORK

Power

Voltage	Current
12VDC	195mA
15VDC	146mA
24VDC	91mA
36VDC	67mA

CAUTION: Risk of Electric Shock – More than one disconnect switch may be required to de-energize the equipment before servicing.

- ✓ Connect 12-36V DC to the power terminals labeled DC+ & DC-. Observe proper polarity. For supply connections, use No. 14 AWG wires rated for at least 75°C. **CAUTION:** Do not exceed 36VDC peak.

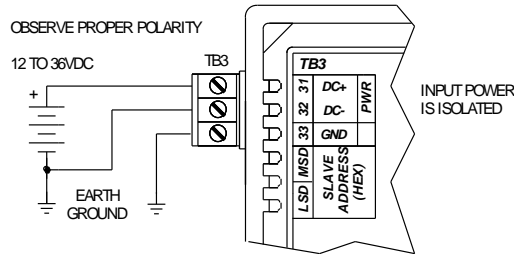

IMPORTANT – External Fuse: If unit is powered from a supply capable of delivering more than 1A to the unit, it is recommended that this current be limited via a high surge tolerant fuse rated for a maximum current of 1A or less (for example, see Bel Fuse MJS1).

Analog Inputs

Input is DC current (961PB), or DC voltage (962PB), according to model number.

Inputs are not isolated channel-to-channel, except for small common mode voltages up to ±4V peak.

- ✓ Connect analog input signals to the input terminals as shown below according to your signal type.

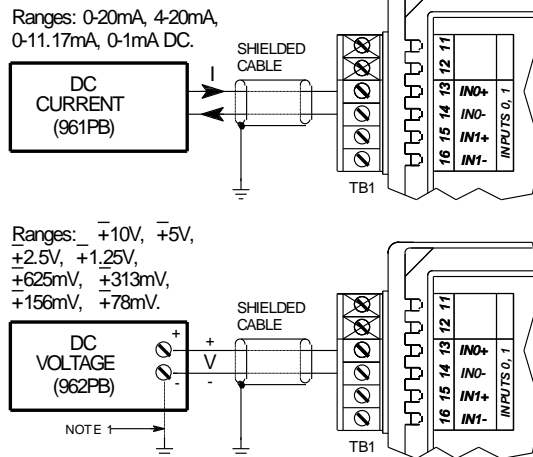

CONNECTIONS

Analog Inputs

Connections to an optional AC current sensor or two-wire transmitter (961PB Only).

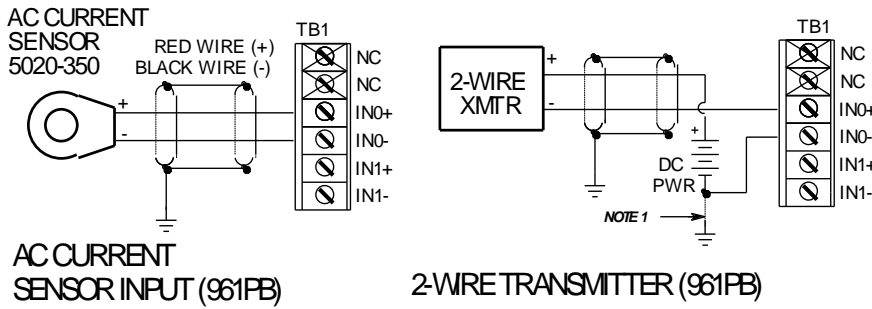

AC CURRENT SENSOR INPUT (961PB)

2-WIRE TRANSMITTER (961PB)

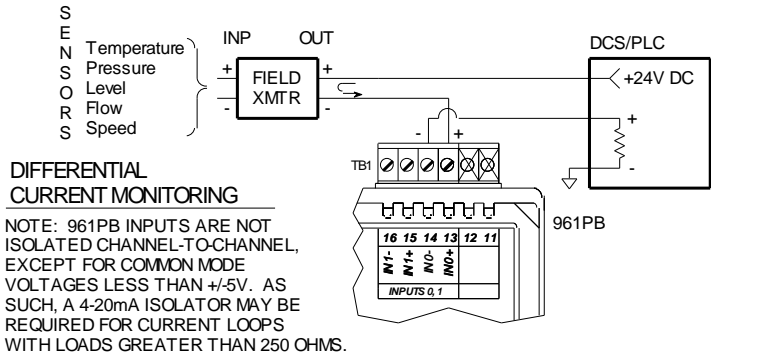

DIFFERENTIAL CURRENT MONITORING

Although the 961/962PB is not isolated channel-to-channel, it does provide common mode isolation for low voltages in range of $\pm 5V$. This makes it useful for differential current and voltage monitoring applications similar to the examples shown here.

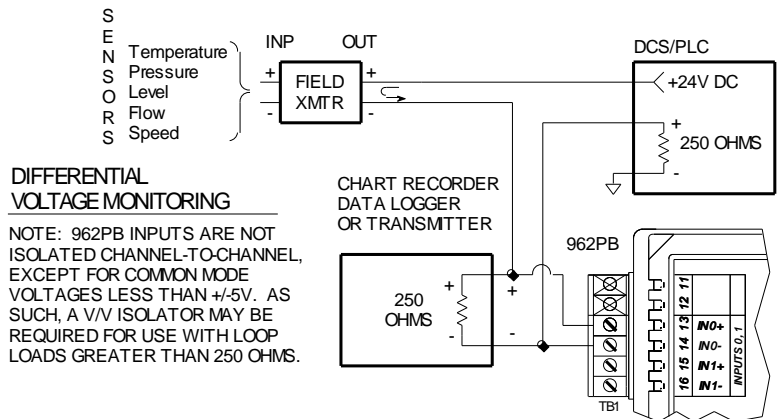

DIFFERENTIAL VOLTAGE MONITORING

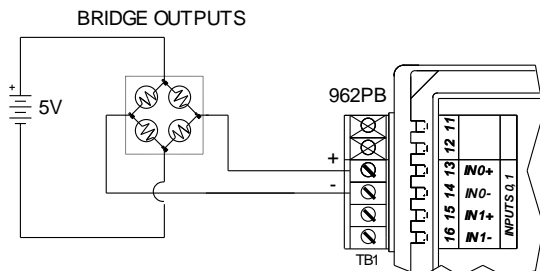

DIFFERENTIAL VOLTAGE MONITORING

NOTE: 962PB INPUTS ARE NOT ISOLATED CHANNEL-TO-CHANNEL, EXCEPT FOR COMMON MODE VOLTAGES LESS THAN +/-5V. AS SUCH, LIMIT BRIDGE EXCITATION TO 5V OR LESS.

Earth Ground

Warning: To comply with safety and performance standards, use shielded cable and connect earth ground as noted. Failure to use good wiring and grounding practices may be unsafe and hurt performance.

- ✓ Connect Earth Ground as shown in the connection drawings above. Additionally, ground the ProfiBus cable as shown in the drawing below.

The ground connections noted are recommended for best results. If sensors are already grounded, use caution and avoid making additional ground connections which could create ground loops.

The plastic module housing does not require earth ground.

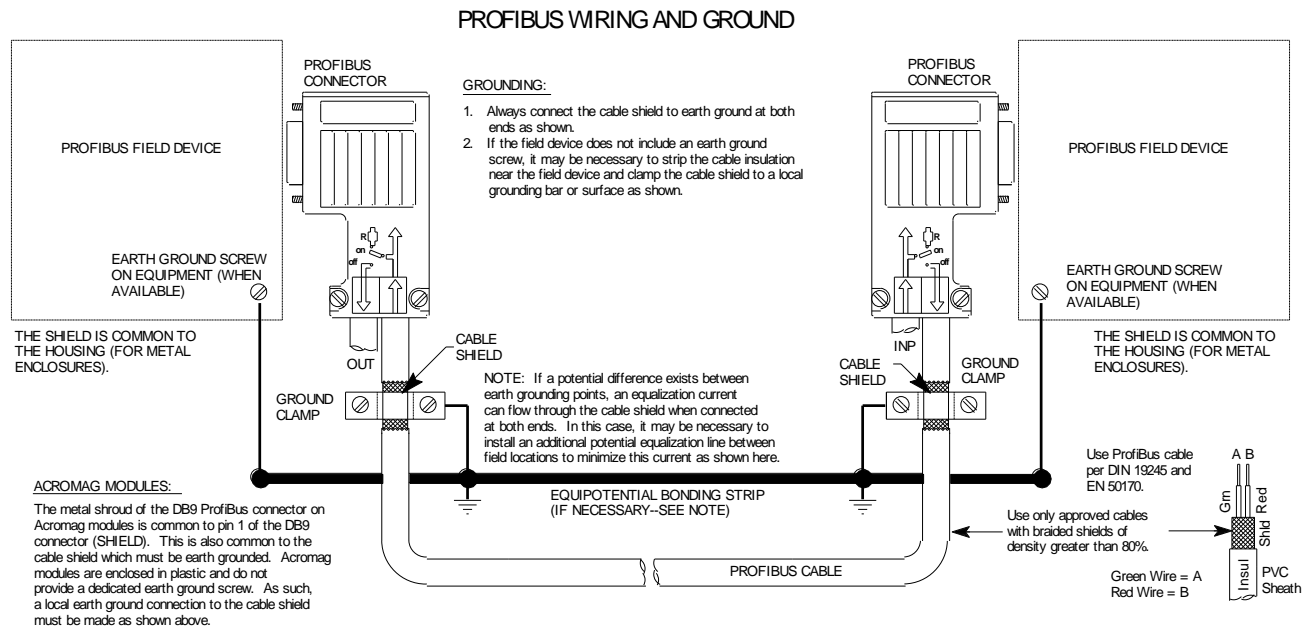

TROUBLE-SHOOTING

The module routinely performs internal diagnostics following power-up or reset. During this period, the green "Run" LED will flash for a moment. If the diagnostics complete OK, the "Run" LED will stop flashing after a few seconds and remain ON. This indicates the unit is operating normally. Once the unit has passed through the initialization, parameterization, and configuration states, and is in data exchange mode, the yellow BUS LED will be ON. If the BUS LED is OFF and the unit is connected to the network, then this may be indicative of an initialization problem (check the address setting).

Tips For Building ProfiBus Networks

- Follow the ProfiBus installation guidelines.
- Use the recommended cable and connectors of the standard.
- Verify that none of the wires are broken or shorted.
- Don't mix the A & B lines. Use green wire for A and red wire for B.
- Do not exceed the recommended segment length for the baud rate.
- Make sure that there are no more than 32 RS-485 devices per segment (including the master device and the repeater).
- Check for proper termination of all copper-wire network segments (an RS-485 segment must have a termination resistor at both ends of the segment only).

- All activated terminations must be powered all the time. If this is not possible, then consider using an active-termination box.
 - Check whether the station address is set to the correct value.
 - If your network connects between buildings or runs through hazardous environments, consider the use of fiber-optics.
 - Avoid drop lines and keep their length within the specified maximum. For T-drops, consider using repeaters and active-bus terminations.
1. Incorrect slave address set at the slave.
 2. Profibus connector between the master and slave has its termination switch turned ON.
 3. Incorrect module configuration sent to slave.
 4. Configuration is based on outdated GSD file information.

Tips For Building Profibus Networks

Top Four Common Profibus Problems

There are several models of handheld devices on the market that simplify the installation and troubleshooting of Profibus networks. The more sophisticated units include LCD displays that read out errors directly. Two of these of these devices are referenced below:

Troubleshooting Tools

Hand-Held Profibus Network Maintenance Tools

Manufacturer	Part Number	Special Features
Siemens	BT 200	Primarily a Cable Tester
Comsoft	NetTest II Set 4000-7-06C-J	Includes DP Mono-Master Functionality

In general, these devices can be used to check the network wiring before devices are connected to the bus and are often used to indicate:

- Whether the A and B lines have been switched.
- Whether a short exists between the A & B lines and shield.
- The occurrence of a wire-break in the A or B line, or shield line.
- Improper termination.

These devices can also be used to check the RS-485 interface of Profibus devices after they have been connected. They may include the following functions:

- The ability to create a list of all stations connected to a network (useful for identifying missing or “offline” devices).
- Test individual stations and help identify duplicate addresses.
- Measure the distance along a network segment to verify whether it complies with the Profibus requirements for distance and data rate.
- Detect signal reflections along the network, useful for locating bus line interruptions and discontinuities.

Acromag strongly suggests the use of these tools for building and maintaining Profibus networks.

Note that Profichip also offers a Profibus connector (PA003100) that includes 4 network diagnostic LED's that may be helpful in trouble-shooting your network (see table below).

Using Connectors To Troubleshoot

Standard 9-pin Profibus connectors with integrated termination resistors are helpful for troubleshooting segments of the network. In most of these connectors, the outgoing portion of the connector is disconnected when the termination resistors are switched ON. As such, you can selectively disable segments of the network until you find the branch that is causing the problem. For example, if your handheld unit is connected to the beginning of a network and indicates a wire break, you can selectively switch off portions of the network and recheck your handheld unit to help pin point the portion of the network that is causing the problem. Below are some Profibus connectors that we recommend:

Preferred Bus Connectors

Mfg	Part Number	Special Features
Siemens	6ES7972-0BA12-0XA0	Switchable Termination
Siemens	6ES7972-0BB12-0XA0	Adds PB Interface (Piggy Back DB9 For Diagnostic Connection)
Profichip	PA003100	Adds PB Interface Plus 4 Diagnostic LED's For Trouble-Shooting.

Diagnostics Function

Profibus includes a rich diagnostic function that can be used to troubleshoot Profibus devices. This function contains 6 bytes of standard diagnostic information, plus up to an additional 238 bytes of device specific diagnostic information. Most configuration tools support this command and can read the diagnostic information from the Profibus device.

Diagnostics Table

If your problem still exists after checking your wiring and reviewing this information, or if the evidence points to another problem with the unit, an effective and convenient fault diagnosis method is to exchange the module with a known good unit. Acromag's Application Engineers can provide further technical assistance if required. Complete repair services are also available from Acromag.

SYMPTOM	POSSIBLE CAUSE	POSSIBLE FIX
<i>Yellow BUS LED does not light.</i>	Initialization Problem. LED ON if module in data exchange state. Both the internal EEPROM and external address switches are set to an address of 126.	Check station address. Is GSD file correct? Check for wiring error. Module is awaiting Set Slave Address command in order to complete initialization. Alternately, set switches from 0-125 and re-power.
<i>Cannot communicate.</i>	Power ON at module and/or converter? Is address correct?	Check power. Is green RUN LED ON? Check slave address setting.
	Is the termination switch of the Profibus connector at the prior node turned on?	Switch Termination on only at the ends of the network. With termination on, the outgoing connections are disconnected from the network chain.
<i>Yellow BUS LED turned OFF.</i>	Communication Halted.	Cycle power to reset unit. Investigate grounding.
<i>Continuous flashing green RUN LED.</i>	Internal firmware problem.	Return module for service.
<i>Many Communication Errors.</i>	Missing Termination Resistors?	Termination resistors must be placed only at both ends of a network or segment.
	Is baud rate too high for distance?	Maximum distance is limited below 1200 meters as baud rate is increased above 93.75Kbps (see Table).

CALIBRATION

There are six calibration channels for these models. The following table gives the calibration values for the input ranges of these models. These are the input signals required to calibrate the range endpoints. Your success in recalibrating the input will depend upon the accuracy and precision of your signal source. Note that on the 961PB-2006, the 4-20mA range is a sub-range of the 0-20mA range and is automatically calibrated at the same time. If calibration is required, it is recommended that all ranges of the unit be done.

IMPORTANT: For best results, be sure to use a precision signal source capable of reproducing the nominal endpoint signals shown below, at least as accurate as the module itself (better than ±0.1% of span). Always allow the module to warm up a few minutes prior to calibration.

IMPORTANT: *This module has already been calibrated at the factory and recalibration is not normally required, except as necessary to correct for long term component aging, or to satisfy your company's maintenance requirements. Do not attempt to recalibrate this module unless absolutely required, as miscalibration will negatively affect the module's performance.*

RANGE	ZERO Calibration	FS Calibration
Model 961PB-2006		
0-20mA DC, 4-20mA DC	1.0mA	20.0mA
0-11.17mA DC	1.0mA	11.17mA
0-1mA DC	0.25mA	1.00mA
Model 962PB-2006		
±10V DC	-10000.0mV	10000.0mV
±5V DC	-5000.0mV	5000.0mV
±2.5V DC	-2500.0mV	2500.0mV
±1.25V DC	-1250.0mV	1250.0mV
±625mV DC	-625.0mV	625.0mV
±313mV DC	-312.50mV	312.50mV
±156mV DC	-156.25mV	156.25mV
±78mV DC	-78.13mV	78.13mV

These models have two I/O Configuration definitions in their GSD files, one for normal operation, and another for accomplishing calibration. The normal data exchange definition supports 6 input words (12 input bytes representing your measured values). A second calibration definition supports 6 input words and 6 output words. The master software will allow you to choose which mode the slave will assume—Input Mode or Configuration Mode. The method used to transfer information between the master and slave will vary widely between systems. The steps below represent the minimum steps necessary to accomplish software calibration. If you choose to perform calibration and select Configuration Mode, the master will download the 6I/6O word configuration during the startup sequence, and the module may then be calibrated as follows:

1. With your master software, select the "Configuration Mode" from the GSD file when setting up the master to communicate with the module.
2. With user parameterization bytes 0 & 1, set the ranges that are to be calibrated.
3. Apply the zero calibration signal (see table of prior page) to the input to be calibrated and allow the input to settle a few seconds.
4. Write FFH into the low-order byte of the channel's output word several times (to ensure transmission). In Configuration Mode, the module will automatically calibrate the channel's zero value when FFH is detected. Then write 00H into the low-order byte to complete zero calibration.

CALIBRATION

5. Apply the full-scale calibration signal (Cal Hi, see table) to the input to be calibrated and allow the input to settle a few seconds.
6. Write FFH into the high-order byte of the channel's output word several times to ensure transmission. In Configuration Mode, the module will automatically calibrate the channel's full-scale value when FFH is detected. Then write 00H into the high-order byte to complete full-scale calibration.
7. Repeat steps 3-6 for the other channels of the same range.
8. With user parameter bytes 0 & 1, select the next range to be calibrated.

Note (961PB): The 4-20mA range is calibrated when the 0-20mA range is calibrated and is not calibrated separately. All other ranges are calibrated separately.

9. Repeat steps 3-7 for all channels of this range.
10. Repeat steps 8-9 until all input ranges have been calibrated.
11. When finished calibrating, use the master software to return the module to the normal "Input Mode" to prevent miscalibration.

After completing calibration, the module should be reconfigured as required and placed in the normal "Input Mode" configuration (I/O configuration is 6 input words only). In general, your software allows you to select the normal "Input Mode" configuration, and the slave will then be taken off-line by the master and reconfigured. If reconfiguration is successful, the slave module will pass to the data exchange state with a normal I/O configuration.

TECHNICAL REFERENCE

- **PTO Certified** - Unit certified by the Profibus Trade Organization.
- **Safety Agency Approvals & PTO Certification** – CE, UL, & cUL listed, plus Class 1; Division 2; Groups A, B, C, D approvals.
- **Fully Independent Slave w/ Direct I/O Connection** – Self-contained unit does not require special bus couplers, power supply, or rack mount to operate.
- **Plug-In Terminal Blocks & DIN-Rail Mount** - Make mounting, removal, and replacement easy.
- **Industry Standard ASIC** – Uses Siemens SPC3 intelligent ASIC to talk Profibus.
- **Isolated RS485/Profibus Network Interface** – Highly immune to noise and can operate over long distances. Allows many modules to network together.
- **Auto-Baud Rate Detection** – The baud rate is set automatically.
- **High-Speed Data Rates** – Half-duplex RS485 up to 12M baud.
- **Includes RTS Support** – Profibus interface includes the optional RTS (Request-To-Send) direction control.
- **Flexible Multi-Range Analog Inputs** - Accepts either DC current or DC voltage, according to model number.
- **Range Variability** – The first 3 channels must share the same range, but this can be different than the range of the last 3 channels.
- **Optional AC Current Input (961PB Only)** - An optional AC current sensor can be purchased separately to support AC current inputs.
- **Precise High-Resolution A/D Conversion** – Modules use high-resolution, low noise, sigma-delta analog-to-digital conversion for high accuracy and reliability.
- **Nonvolatile Reprogrammable Memory** – Allows the functionality of this device to be reliably reprogrammed thousands of times.
- **Fully Isolated** – Input channels (as a group), network, and power are all isolated from each other for safety and increased noise immunity.
- **LED Indicators** – A green LED indicates power. A yellow bus status LED indicates proper network connection.
- **Watchdog Timer Built-In** – Standard for the ASIC and operates in the data exchange mode if communication with the master is lost.
- **Self-Diagnostics & Diagnostic Watchdog** - For easy maintenance and troubleshooting. Includes a hardware watchdog timer built into the microcontroller that causes it to initiate a self reset if the controller ever “locks up” or fails to return from an operation in a timely manner.
- **Wide-Range DC-Power** – Diode-coupled for use with redundant supplies, and/or battery back-up.
- **Hardened For Harsh Environments** - For protection from RFI, EMI, ESD, EFT, & surges. Has low radiated emissions per CE requirements.
- **Wide Ambient Operation** – Reliable over a wide temperature range.

KEY FEATURES

HOW IT WORKS

These input modules provide up to 6 process current (961PB), or 6 differential DC voltage (962PB) input channels, and an isolated RS485 Profibus interface for configuring and monitoring the input channels. The current input model uses precision 24.9Ω current sink resistors across the inputs. Voltage input models use 10:1 precision resistor voltage dividers at the input. A multiplexer is used to connect each input voltage to an A/D converter (separate A/D channels serve 3 input channels each). The A/D converter then applies appropriate gain to these signals, performs analog-to-digital conversion, and digitally filters the signals. The digitized A/D signal is then transmitted serially to a microcontroller. The microcontroller completes the transfer function according to the input range per its embedded program. Configuration and calibration parameters are stored in non-volatile memory integrated within the microcontroller. These modules implement the Profibus protocol via an industry-standard SPC3 ASIC from Siemens. This ASIC acts like a RAM or UART chip to the internal microcontroller and completely handles the requirements of the protocol standard. The ASIC will transfer network data to the microcontroller and automatically provide the response to the bus. The ASIC handles the Profibus protocol and communicates with the network via an optically isolated RS485 transceiver. A wide input switching regulator (isolated flyback) provides isolated power to the input circuit and the RS485 port. Refer to the simplified schematic below to gain a better understanding of the circuit.

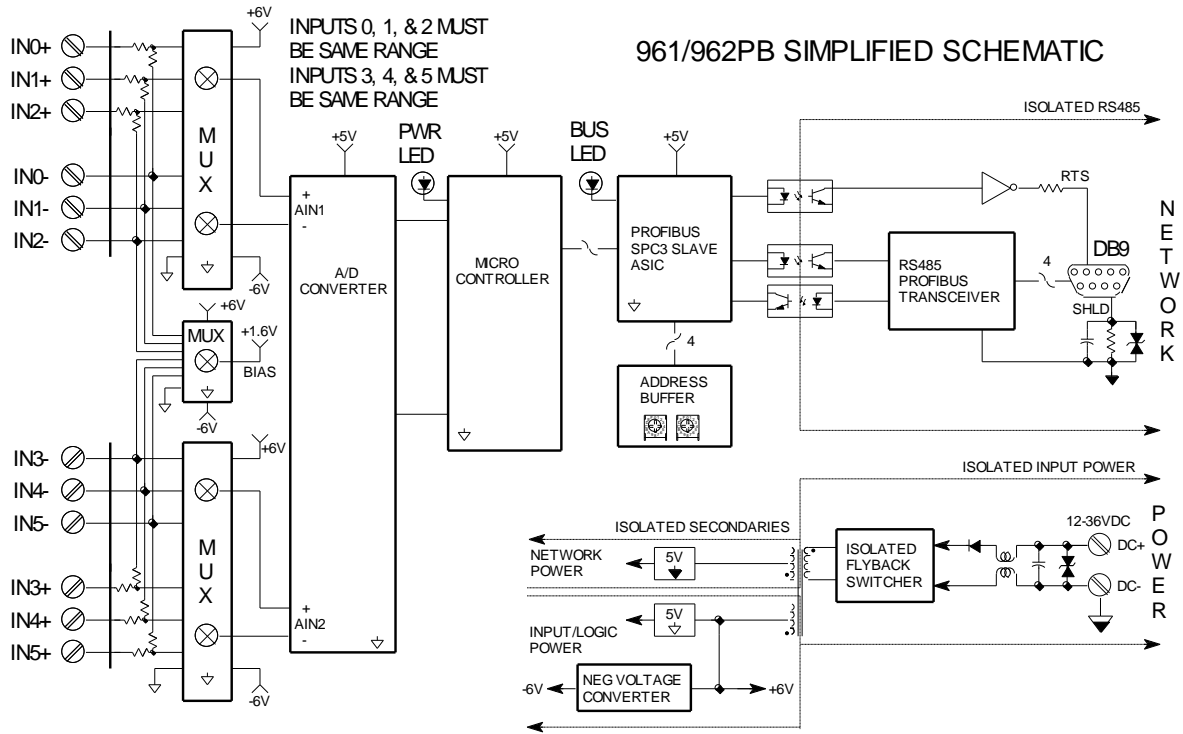

These DIN-rail mount, ProfiBus DP slave, input modules will condition up to six differential DC current (961PB) or DC voltage (962PB) input signals, and provide an isolated RS485/ ProfiBus network interface. Units are DC-powered and include reverse polarity protection. Inputs (as a group), network, and power are isolated from each other. Non-volatile reprogrammable memory in the module stores configuration and calibration information.

The ProfiBus model prefix "900" denotes the Series 900. The "PB" suffix denotes ProfiBus. Select 961PB for current input, and 962PB for voltage input. The four digit suffix of this model number represents the following options, respectively: "2" = ProfiBus DP; "0" = Default; "06" = 6 Channels.

Up to six process current or voltage input channels, according to model number. The unit can be configured to accept one of several input ranges at each group of 3 channels as described below. The unit must be wired and configured for the intended input type and range (see Connections Section for details). The following paragraphs summarize this model's input types, ranges, and applicable specifications.

DC Current (961PB Only): Configurable for 0 to 20mA, 4-20mA, 0-11.17mA, and 0-1mA DC nominal input ranges. A precision 24.9 Ω current sink resistor converts the input current to a voltage that is processed by the A/D converter. An optional external sensor is required to monitor AC current signals (Acromag Model 5020-350). This sensor generates a DC milliamper signal of 0 to 11.17mA for the module (see Table 1 below for scaling to AC current).
Current Input Reference Test Conditions: 4 to 20mA current input; ambient temperature = 25°C; 24VDC supply.
Input Overvoltage Protection: Bipolar Transient Voltage Suppressers (TVS), 5.2V clamp level typical.

AC Current Sensor (Model 5020-350, For Use With 961PB): This sensor is a toroidal instrument transformer that converts a sinusoidal 50-60Hz AC current signal into a low level DC milliamper signal of 0 to 11.17mA. The input AC current range is a function of the number of turns placed through the toroid as shown in Table 1 below. This sensor is isolated and requires no calibration or adjustment. When used with a 961PB module, it provides redundant input isolation and may facilitate input-to-input isolation of this six channel unit.

Table 1: AC Current Sensor Turns & Range

AC Current Input Range	Primary Turns	Sensor Output (Red/Black Wires)
0 to 20A AC	1	0 to 11.17mA DC
0 to 10A AC	2	"
0 to 5A AC	4	"
0 to 2A AC	10	"
0 to 1A AC	20	"

The output wires of this sensor are polarized with red as (+) plus and black as (-) minus. Normally these output wires are attached to one end of a user supplied cable while the other end connects to the 961PB's process current input terminals.

SPECIFICATIONS

Model Numbers

961PB-2006 (Current)
 962PB-2006 (Voltage)

Analog Inputs

Analog Inputs

Input Burden: A function of the wire gauge resistance used for primary turns (the current carrying wire being monitored).

AC Current Sensor to Transmitter Wiring Distance: 400 feet maximum for 18 gauge wire. Other wire gauges can be used as long as the resistance of both wires is less than 5Ω.

Input Overload: The AC current sensor will withstand overload conditions as follows:

- 20 times full scale for 0.01 seconds.
- 10 times full scale for 0.1 seconds.
- 5 times full scale for 1.0 second.

DC Voltage (962PB Only): A 10:1 input divider is installed at the input (utilizing divider resistor values of 100K and 10.5K). User-configurable for the nominal bipolar DC voltage ranges of ±10V, ±5V, ±2.5V, ±1.25V, ±625mV, ±313mV, ±156mV, and ±78mV DC.

Input Impedance: 110.5KΩ.

Voltage Input Reference Test Conditions: -10 to 10V DC input; ambient temperature = 25°C; 24VDC supply.

Input Overvoltage Protection: Bipolar Transient Voltage Suppressors (TVS), 18V clamp level typical.

General Specifications

Accuracy: Better than ±0.05% of span, typical for nominal input ranges (except 0-1mA). This includes the effects of repeatability, terminal point conformity, and linearization, but does not include sensor error.

Measurement Temperature Drift: Better than ±50ppm/°C (±0.005%/°C).

Analog to Digital Converter (A/D): A 16-bit Σ-Δ converter.

Resolution: 0.005% or 1 part in 20000 (961PB), 0.0025% or 1 part in 40000 (962PB, full bipolar range).

Input Conversion Rate: 80ms per channel, or 480ms for six input channels.

Input Filter: Normal mode filtering, plus digital filtering optimized and fixed per input range within the Σ-Δ ADC.

Input Filter Bandwidth: -3dB at 3Hz, typical.

Noise Rejection (Normal Mode): 40dB @ 60Hz, typical with 100Ω input unbalance.

Noise Rejection (Common Mode): 140dB @ 60Hz, typical with 100Ω input unbalance.

Agency Approvals

Profibus Trade Organization (PTO): Certified.

Safety Approvals: CE marked (EMC Directive 89/336/EEC); UL Listed (UL508, UL1604); cUL Listed (Canada Standard C22.2, No. 142-M1987 & 213-M1987); Hazardous Locations: Class 1; Division 2; Groups A, B, C, and D.

Enclosure and Physical

Dimensions: 1.05 inches wide, 4.68 inches tall, 4.35 inches deep. Refer to the dimensions drawing at the front of this manual.

DIN Rail Mount: Type EN50022; "T" rail (35mm).

I/O Connectors: Removable plug-in type terminal blocks rated for 15A/300V; AWG #12-24 stranded or solid copper wire.

Case Material: Self-extinguishing NYLON type 6.6 polyamide thermoplastic UL94 V-2, color beige; general purpose NEMA Type 1 enclosure.

Printed Circuit Boards: Military grade FR-4 epoxy glass.

Shipping Weight: 1 pound (0.45 Kg) packed.

Network Connector: 9-pin D-Sub connector (female) with metal housing and 4-40 jack screw support.

D-Sub Pin	Signal	Description
1	SHLD	Shield (Connect to Earth Ground)
2	NC	No Connection
3	A	Data A (TxD/RxD+)
4	RTS	Request To Send
5	GND	RS485 Logic Ground
6	+5V	+5V
7	NC	No Connection
8	B	Data B (TxD/RxD-)
9	NC	No Connection

Operating Temperature: -25°C to +70°C (-13°F to +158°F).

Storage Temperature: -40°C to +85°C (-40°F to +185°F).

Relative Humidity: 5 to 95%, non-condensing.

Power Requirements: 11-36V DC SELV (Safety Extra Low Voltage).

Observe proper polarity. Current draw may decrease up to 10% as the baud rate is increased to 12MB (data below is at 9600 baud).

Supply	961PB-2006 or 962PB-2006 Current Draw (9600bps)
12V	172mA Typical / 195mA Maximum
15V	133mA Typical / 146mA Maximum
24V	83mA Typical / 91mA Maximum
36V	61mA Typical / 67mA Maximum

CAUTION: Risk of Electric Shock – More than one disconnect switch may be required to de-energize equipment before servicing.

Power Supply Effect:

Volts: Less than $\pm 0.001\%$ of output span change per volt for rated power supply variations.

60/120 Hz Ripple: Less than 0.01% of output span per volt peak-to-peak of power supply ripple.

Isolation: Input channels (as a group), power, and network circuits are isolated from each other for common-mode voltages up to 250VAC, or 354V DC off DC power ground, on a continuous basis (will withstand 1500VAC dielectric strength test for one minute without breakdown). Complies with test requirements of ANSI/ISA-82.01-1988 for voltage rating specified.

Installation Category: Designed to operate in an Installation in a Pollution Degree 2 environment with an installation category (over-voltage category) II rating.

Electromagnetic Interference Immunity (EMI): Measurement shift is less than $\pm 0.25\%$ of input span for interference from switching solenoids, commutator motors, and drill motors.

Electromagnetic Compatibility (EMC) -

Minimum Immunity Per European Norm EN50082-1:

Electrostatic Discharge (ESD) Immunity: 4KV direct contact and 8KV air-discharge to the enclosure port per EN61000-4-2.

Radiated Field Immunity (RFI): 10V/M, 80 to 1000MHz AM and 900MHz keyed carrier, per EN61000-4-3 and ENV50204.

Electrical Fast Transient Immunity (EFT): 2KV to power, and 1KV to signal I/O per EN61000-4-4.

Enclosure and Physical

Environmental

CAUTION: Do not exceed 36VDC peak, to avoid damage to the module.

External Fuse: Select a high surge tolerant fuse rated for 1A or less to protect unit.

Note that input channels are not isolated channel-to-channel, except for small common-mode variations less than $\pm 4V$ peak.

These limits represent the minimum requirements of the standard, but product has typically been tested to comply with higher standards in some cases.

Environmental

Conducted RF Immunity (CRFI): 10V rms, 150KHz to 80MHz, per EN61000-4-6.

Surge Immunity: 0.5KV per EN61000-4-5.

Emissions Per European Norm EN50081-1:

Radiated Frequency Emissions: 30 to 1000MHz per EN55022 Class A

WARNING: This is a Class A product. In a domestic environment, this product may cause radio interference in which the user may be required to take adequate measures.

IMPORTANT: Power, input, and output (I/O) wiring must be in accordance with Class I, Division 2 wiring methods Article 501-4(b) of the National Electrical Code, NFPA 70 for installations in the U.S., or as specified in section 18-1J2 of the Canadian Electrical Code for installations within Canada and in accordance with the authority having jurisdiction.

This equipment is suitable for use in Class I, Division 2, Groups A, B, C, and D, or non-hazardous locations only.

WARNING – EXPLOSION HAZARD – Substitution of components may impair suitability for Class I, Division 2.

WARNING – EXPLOSION HAZARD – Do not disconnect equipment unless power has been switched off or the area is known to be non-hazardous

Communication Interface

Interface Standard: 3-wire RS-485 multi-drop, half-duplex (D, D-bar, and Common), asynchronous.

Command/Response Protocol: Standard ProfiBus DP (Master/Slave) protocol per European Norm EN50170.

Baud Rate: Supported baud rates are 9600, 19.2K, 45.45K, 93.75K, 187.5K, 500K, 1.5M, 3M, 6M, and 12M bits per second, auto-detected. Maximum transmission length is dependent on baud rate selection (range is up to 1200M at 9600bps, or up to 100M at 12Mbps). Refer to the following table for maximum transmission distances at supported baud rates using recommended type A (<30pF/M), or alternately type B (<60pF/M) bus wire (see EN50170):

Baud Rate	NETWORK LENGTH	
	Type A	Type B
9600 bps	1200M	1200M
19.2K bps	1200M	1200M
≤ 93.75K bps	1200M	1200M
187.5K bps	1000M	600M
500K bps	400M	200M
1.5M bps	200M	NA
≤ 12M bps	100M	NA

Parity: Even parity.

Stop Bits: One.

Communication Distance: Up to 1200 meters without a repeater.

Ident_Number: 0703H (962PB-2006), 0704H (961PB-2006).

GSD File: ACRO0704.GSD (961PB-2006), ACRO0703.GSD (962PB-2006).

Maximum Message Size: Up to 32 bytes recommended, extendable up to 244 bytes of data/node/message, plus 11 bytes of overhead (frame).

Profibus Character: 11 bits (1 start bit + 8 data bits + 1 even parity bit + 1 stop bit). Applies to all bytes, including frame bytes.

Bus Idle State: "1" (a start bit causes line to go to "0"). An idle state of at least 33 Tbits (sync-time) must be provided between messages.

Note: 1Tbit at 12Mbaud = 1/12000000bit/sec = 83nsec.

Address: Set via two rotary hexadecimal switches adjacent to the power terminals, or alternately via the Set Slave Address command. Valid setting is 0-125 (7 bits). Address 126 (7EH) is the default factory address and is reserved for commissioning purposes only. Address 127 (7FH) is reserved by the software as a global address for broadcast messages. If the address switches are set to 126 upon power-up (or 126-254), then the unit will retrieve its address from its internal EEPROM rather than the switches. The internal EEPROM setting is modified via the Set Slave Address command. Powering up with switches set to 255 (FFH) will cause the internal EEPROM setting to revert back to 126 (7EH), which may be used to recommission the module. If both the internal EEPROM address and the switches are set to 126 upon power-up (this is the initial state from the factory), the module will await the Set Slave Address command before completing initialization and assuming the data exchange mode.

IMPORTANT (Address Setting): The internal EEPROM address setting and external switch setting is 126 from the factory. As such, the module will await the Set Slave Address command following power-up and will not proceed to exchange data, unless the external switches are instead set to an address from 0-125, or the internal setting is changed to an address from 0-125 via the Set Slave Address command.

Network Capacity: Multi-drop up to 31 modules, plus a host, without a repeater. Up to 125 modules plus a host if four repeaters are used (one for every 31 nodes).

Network Termination: Use 220Ω "A" to "B", plus 390Ω "A" to GND, and 390Ω "B" to +5V. Use ±2%, 0.25W resistors.

LED Indicators:

Run (Green) - Constant ON indicates power is ON and unit is OK.

Flashing ON/OFF indicates unit is performing diagnostics (first few seconds following power-up), or has failed diagnostics (after a few seconds).

Bus (Yellow) – ON indicates unit has completed its initialization sequence and is in the data exchange mode on the network.

Switches:

Slave Address: Two hexadecimal rotary switches are located in the recessed opening adjacent to the power terminals and represent the hex MSB & LSB of the 8 bit slave address. See Address above.

I/O values of Acromag 9xxPB modules are represented by the following simple data types for temperature, percentage, and discrete on/off. Note that when transferring words, data bytes are transmitted using "Big Endian" format (MSB first, LSB second).

Communication Interface

Controls & Indicators

Data Types

Data Types

Data Types	Description
Percentage (This Model)	A 16-bit signed integer value with resolution of 0.005%/lsb. ± 20000 is used to represent $\pm 100\%$. For example, -100% , 0% and $+100\%$ are represented by decimal values -20000 , 0 , and 20000 , respectively. The full possible range is -163.84% (-32768 decimal) to $+163.835\%$ ($+32767$ decimal).
Temperature	A 16-bit signed integer value with resolution of $0.1^{\circ}\text{C}/\text{lsb}$. For example, a value of 12059 is equivalent to 1205.9°C , a value of -187 equals -18.7°C . The maximum possible temperature range is -3276.8°C to $+3276.7^{\circ}\text{C}$.
Discrete	A discrete value is generally indicated by a single bit of an 8-bit byte. The bit number/position typically corresponds to the discrete channel number. Unless otherwise defined for outputs, a 1 bit means the corresponding output is closed or ON, a 0 bit means the output is open or OFF. For active-high inputs, a value of 1 means the input is in its high state (usually $\gg 0\text{V}$), while a value of 0 specifies the input is in its low state (near 0V). For active low inputs, a value of 1 means the input is ON (active low near 0V), while a value of 0 specifies the input is OFF or in its high state (usually $\gg 0\text{V}$).

Module Specific Parameters This model includes three user parameterization bytes (User_Prm_Data) defined as follows:

Note that channels 0, 1, & 2, and channels 3, 4, & 5 (every group of 3 channels) share the same input configuration, but the configuration may vary between the two groups. All parameterization bytes take effect immediately. This model does not include any user defined diagnostic data (Ext_Diag_Data).

Byte	Description	Default
0	Do Not Use – Reserved for SPC3 ASIC.	NA
1	Channel 0, 1, 2 Range Select: 00H = 0-20mA (961PB); $\pm 10\text{VDC}$ (962PB) 01H = 4-20mA (961PB); $\pm 5\text{VDC}$ (962PB) 02H = 0-11.17mA (961PB); $\pm 2.5\text{VDC}$ (962PB) 03H = 0-1mA (961PB); $\pm 1.25\text{VDC}$ (962PB) 04H = Not Defined (961PB); $\pm 625\text{mVDC}$ (962PB) 05H = Not Defined (961PB); $\pm 313\text{mVDC}$ (962PB) 06H = Not Defined (961PB); $\pm 156\text{mVDC}$ (962PB) 07H = Not Defined (961PB); $\pm 78\text{mVDC}$ (962PB) 08H – FFH = Not Defined	00H
2	Channel 3, 4, 5 Range Select: 00H = 0-20mA (961PB); $\pm 10\text{VDC}$ (962PB) 01H = 4-20mA (961PB); $\pm 5\text{VDC}$ (962PB) 02H = 0-11.17mA (961PB); $\pm 2.5\text{VDC}$ (962PB) 03H = 0-1mA (961PB); $\pm 1.25\text{VDC}$ (962PB) 04H = Not Defined (961PB); $\pm 625\text{mVDC}$ (962PB) 05H = Not Defined (961PB); $\pm 313\text{mVDC}$ (962PB) 06H = Not Defined (961PB); $\pm 156\text{mVDC}$ (962PB) 07H = Not Defined (961PB); $\pm 78\text{mVDC}$ (962PB) 08H – FFH = Not Defined	00H
3	Writing 55H to this register will cause the module to restore its original factory calibration. Note that 55H is not stored, but acts as a trigger, as this byte always reads as 00H.	00H
4	Factory Use Only – Do Not Modify.	00H

Revision History

The following table shows the revision history for this document:

Release Date	Version	EGR/DOC	Description of Revision
03 APR 03	A	BC/KLK	Initial release.
28 OCT 03	B	BC/KLK	UL updates per ECN 03J022.
02 NOV 04	C	CAP/KLK	Added latest UL information to manuals and labels per ECN 04J008.
02 FEB 15	D	FJM/ARP	Correction to connectors on DB9 Connections table.